

HIVE BODY

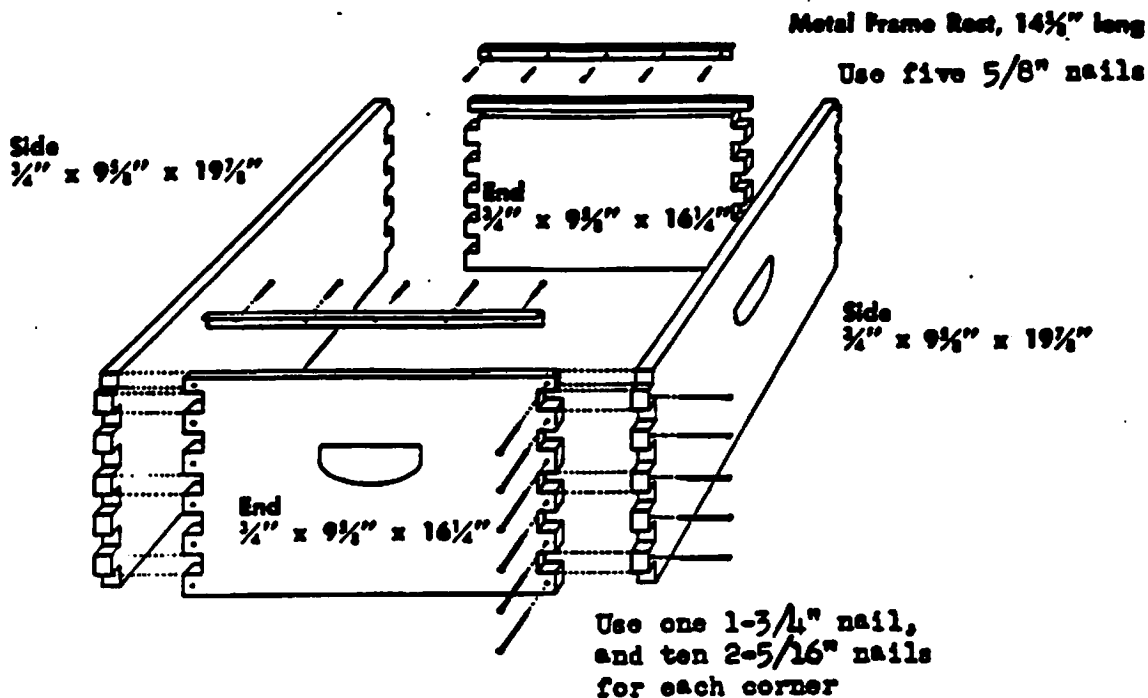

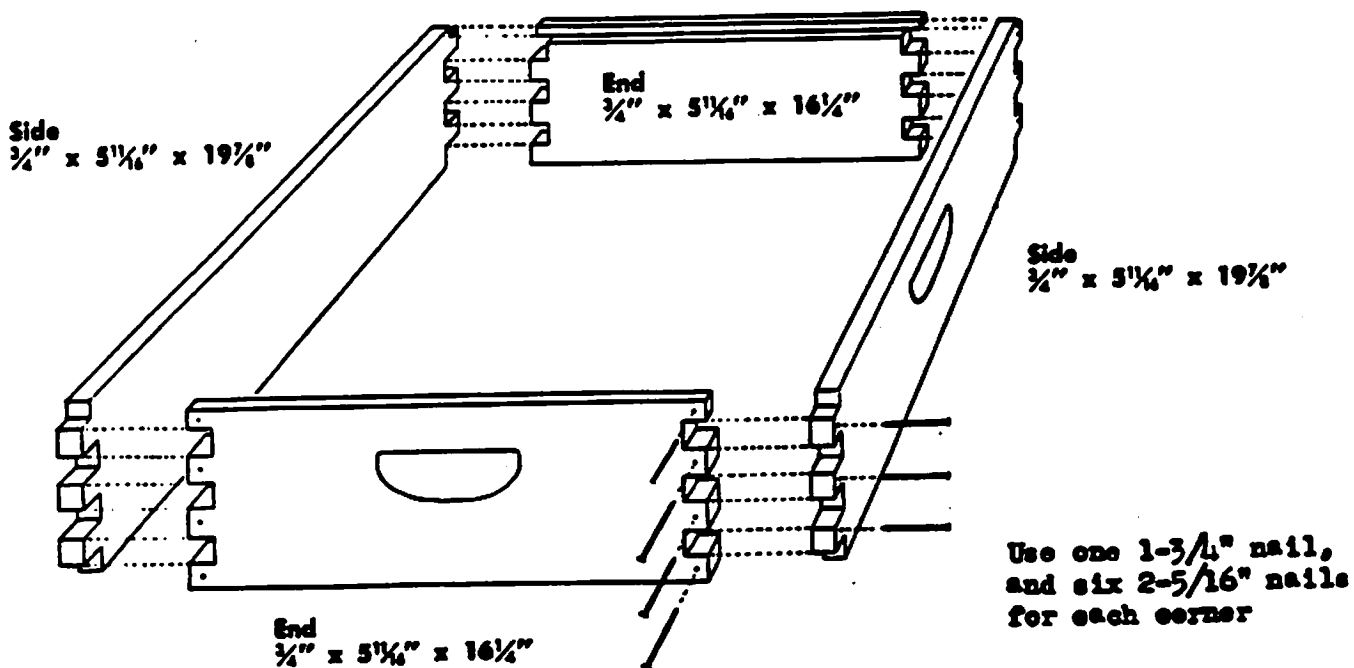



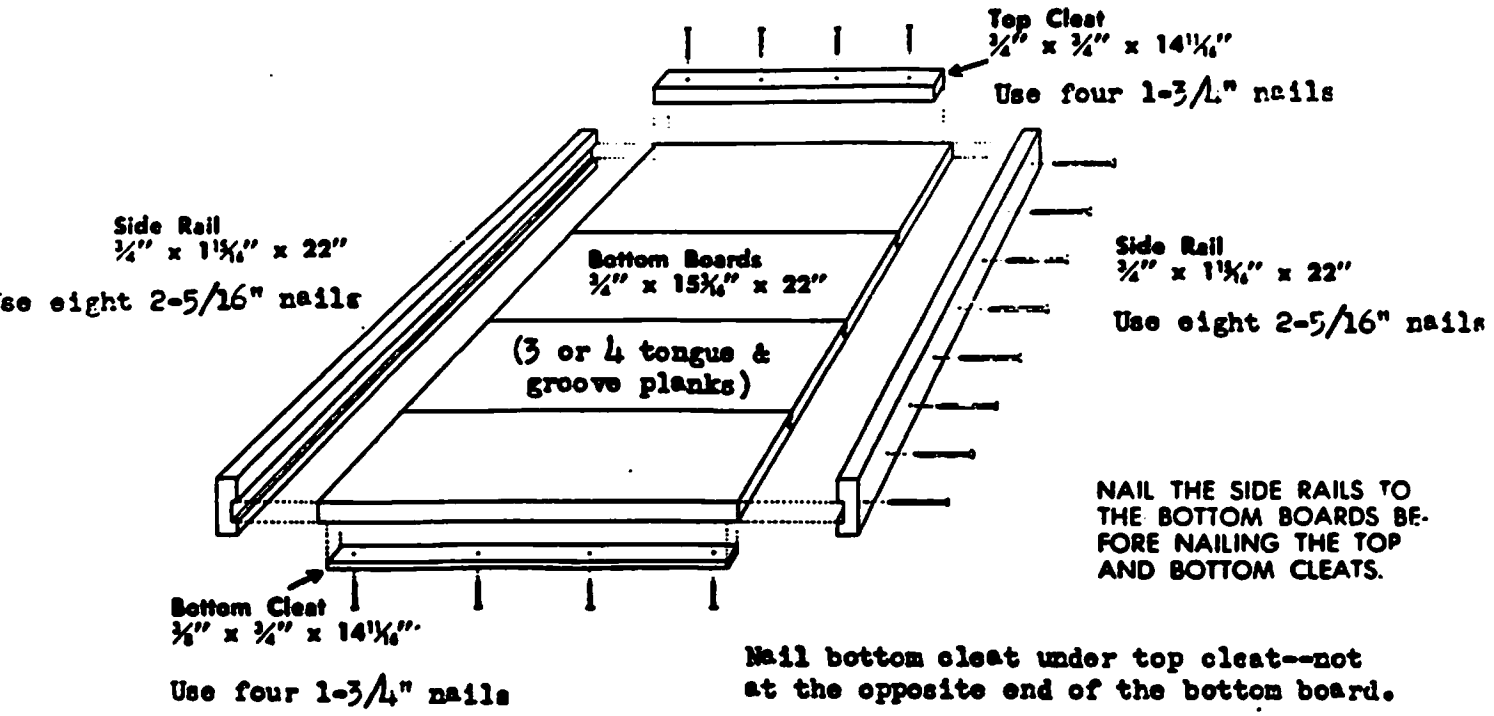

SUPER

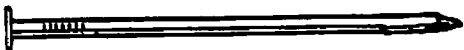

BOTTOM BOARD

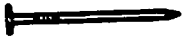

NAIL CHART

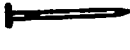
	2- $\frac{5}{16}''$ galvanized
	1- $\frac{3}{4}''$ galvanized
	1- $\frac{3}{8}''$ coated
	1- $\frac{1}{4}''$ coated
	$\frac{7}{8}''$ coated
	$\frac{3}{4}''$ galvanized
	$\frac{5}{8}''$ coated

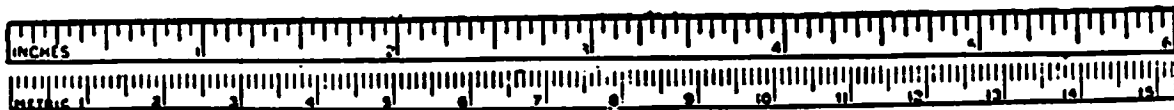

IPM/SCREEN BOTTOM BOARD

SIZED FOR LANGSTROTH BEEHIVE

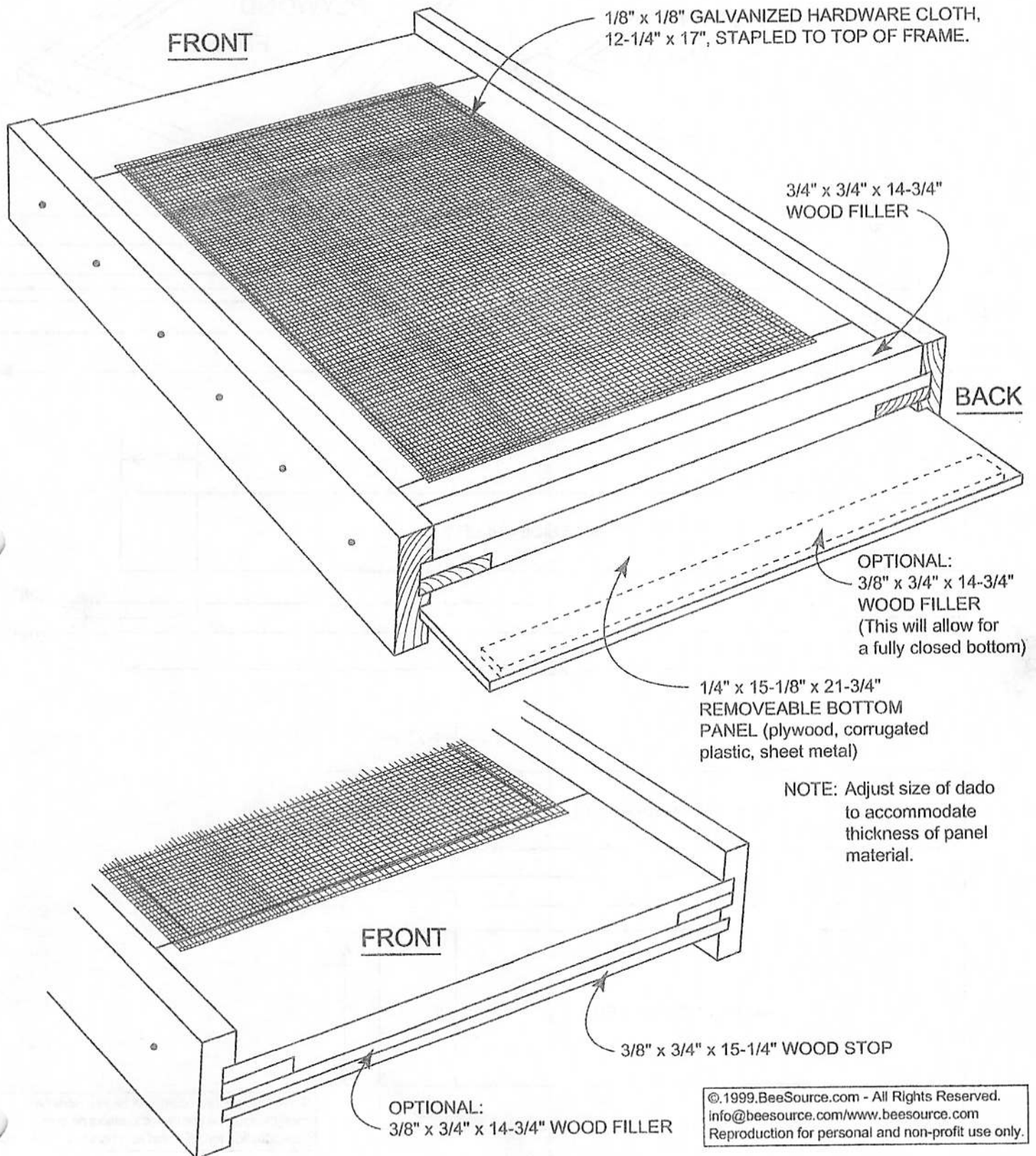

©.1999.BeeSource.com - All Rights Reserved.
info@beesource.com/www.beesource.com
Reproduction for personal and non-profit use only.

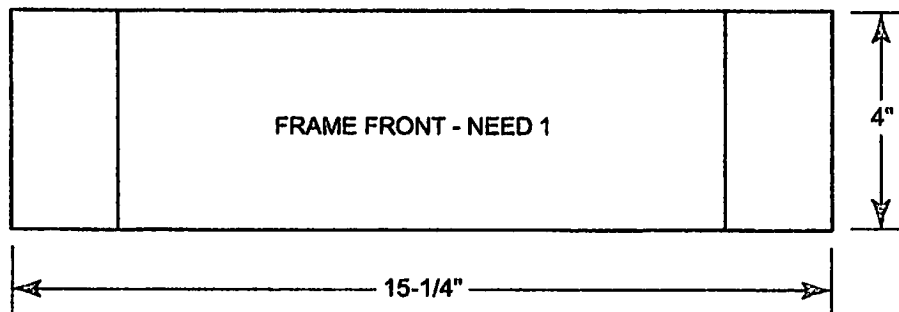
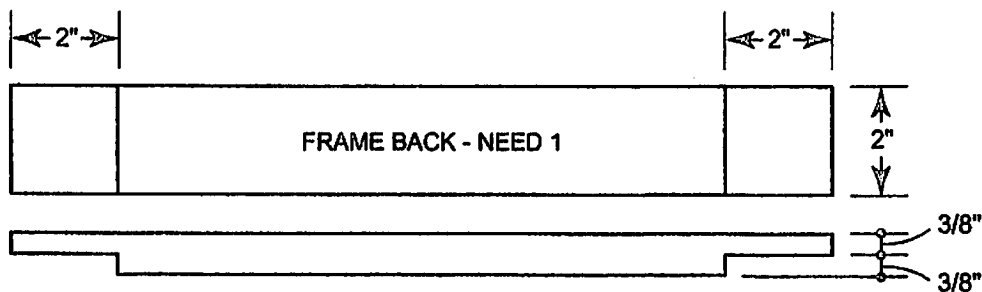
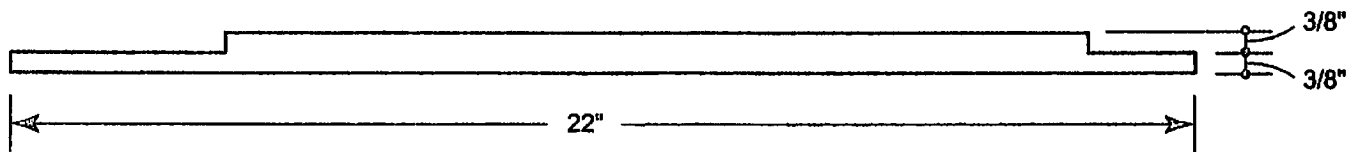
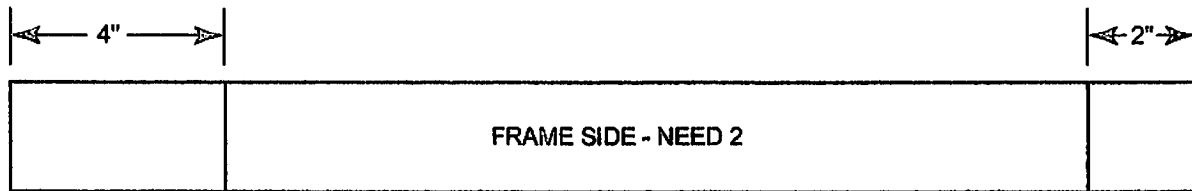
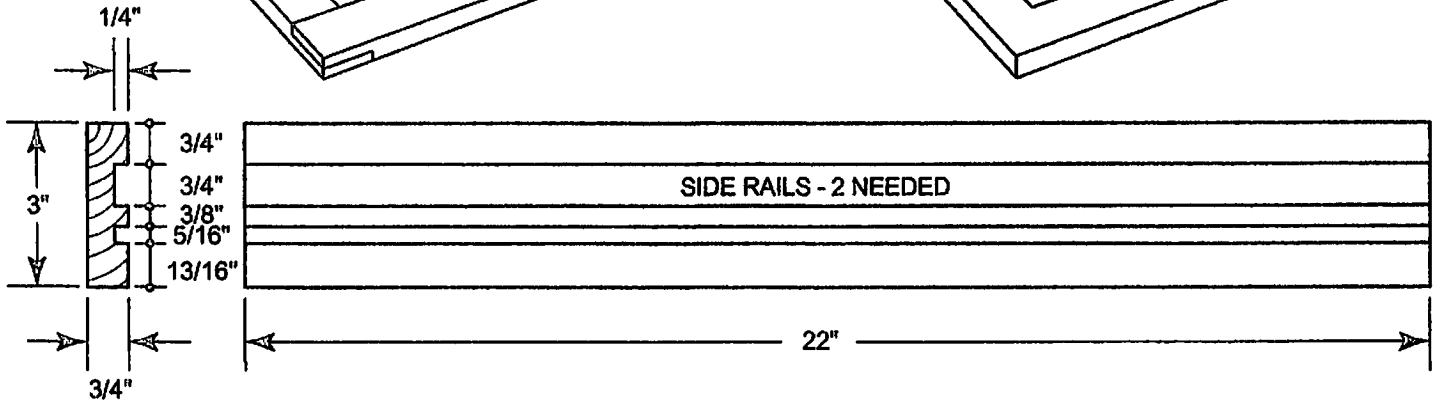
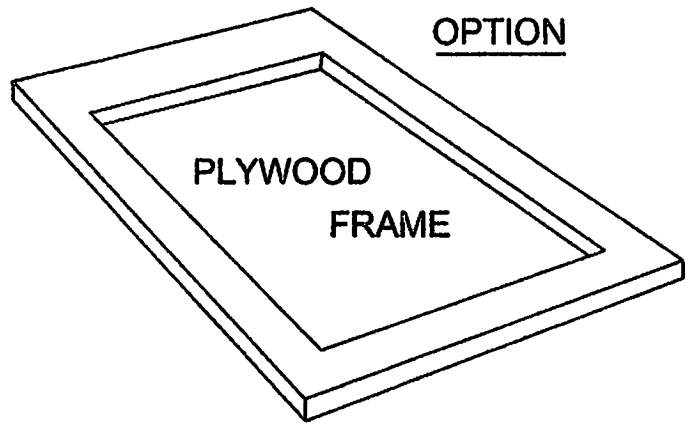
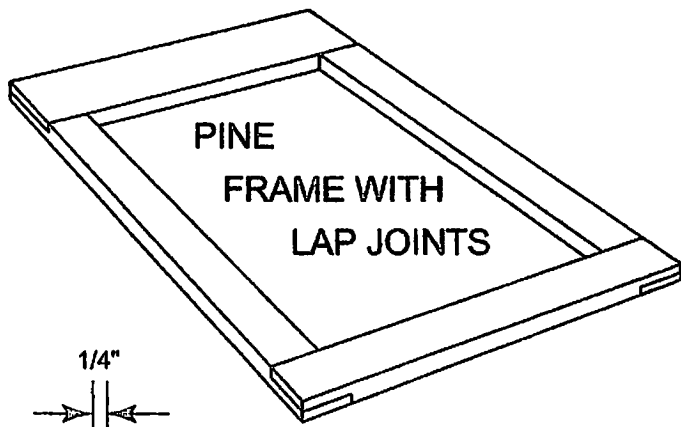

© 1999.BeeSource.com - All Rights Reserved.
 info@beesource.com/www.beesource.com
 Reproduction for personal and non-profit use only.

Removeable Swarm Catching Frames

Frames can be made from old supers. Cut wood strips of 1X pine into 1-1/2" strips. Once you place recovered feral honybee combs in the removeable swarm catching frames, simply take a few frame nails and nail hinged frame together thus making permanebt the combs placed therein. Simply place in super, reconstructing brood nest to allow bees to settle down.

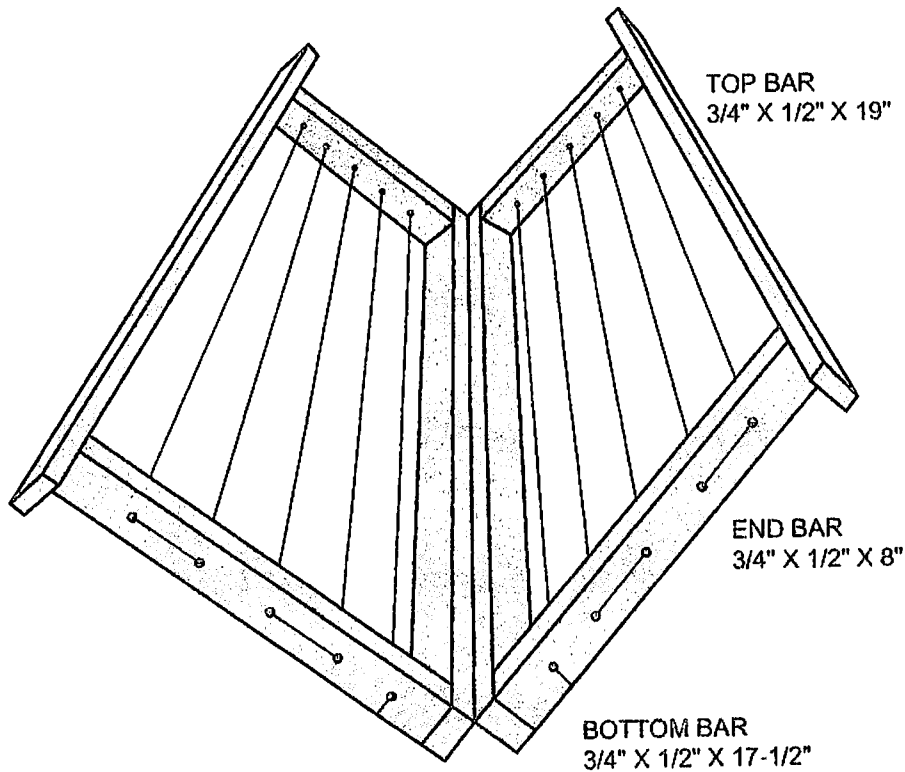

Making a removeable swarm catching frame is quite easy to accomplish.

1. Each half frame is 3/4" wide by 1/2" thick.
2. You can drill 4 to 5 holes to lace frame wire to hold comb that you cut out of feral colony.
3. Mount honey filled comb pieces together in a frame.
4. Mount pollen filled comb pieces together also.
5. Mount brood layed-up pieces together in frames.
6. Place brood frames together in center of super.
7. Place pollen frames on each side of brood frames.
8. Place honey filled frames on outside of pollen and brood frames to complete makeup of supered colony.
9. Remove to calm place for bees to settle down.

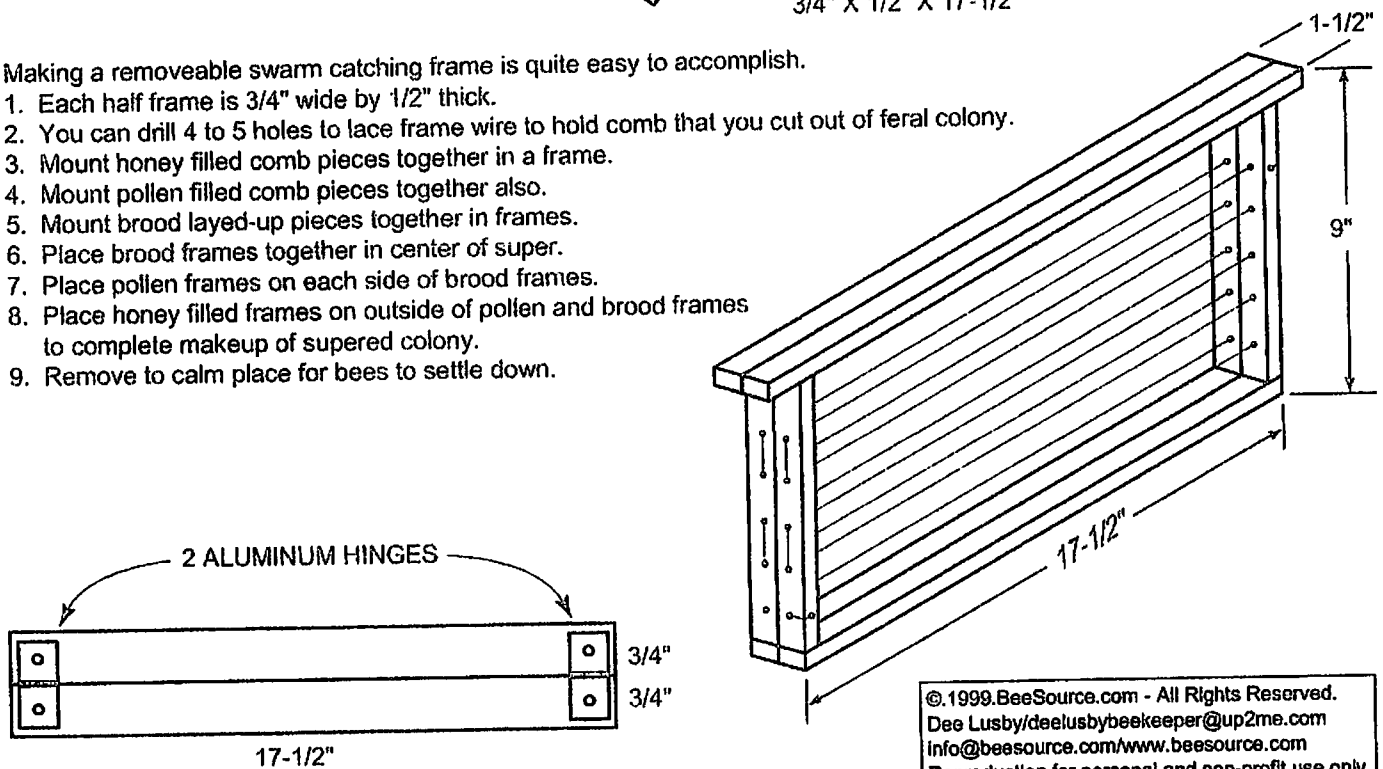

©.1999.BeeSource.com - All Rights Reserved.
Dee Lusby/daelusbybeekeeper@up2me.com
Info@beesource.com/www.beesource.com
Reproduction for personal and non-profit use only.

**DOUBLE THREE
FRAME BROOD
HIVE**
NOT TO SCALE

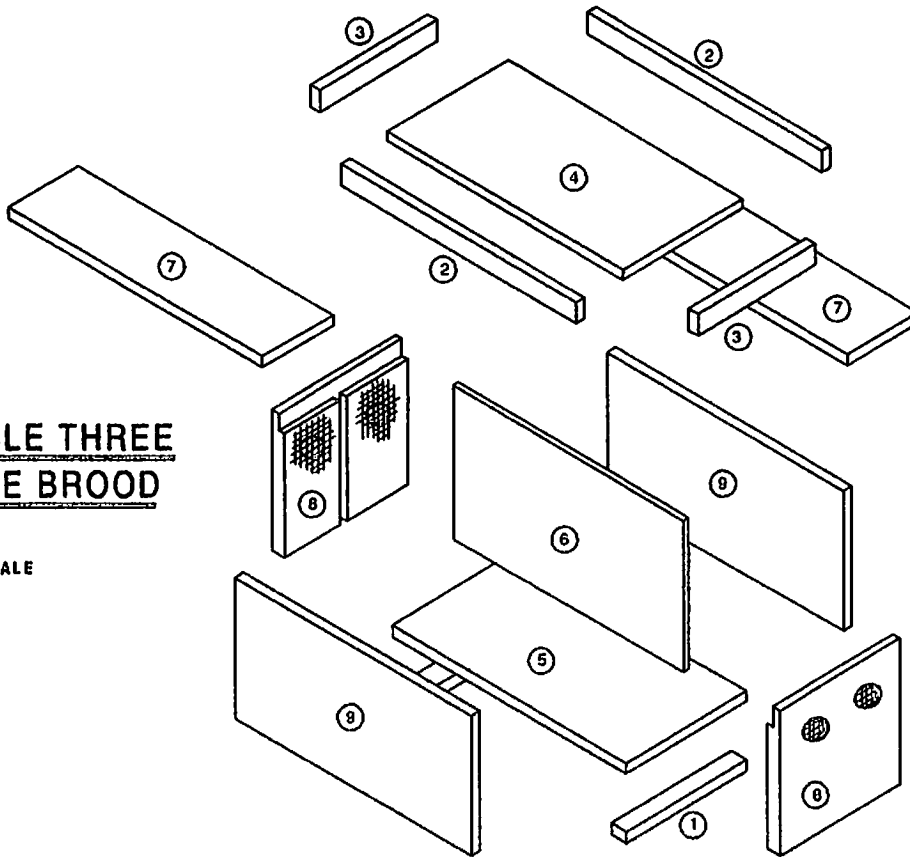

EXPLODED ISOMETRIC VIEW
NOT TO SCALE

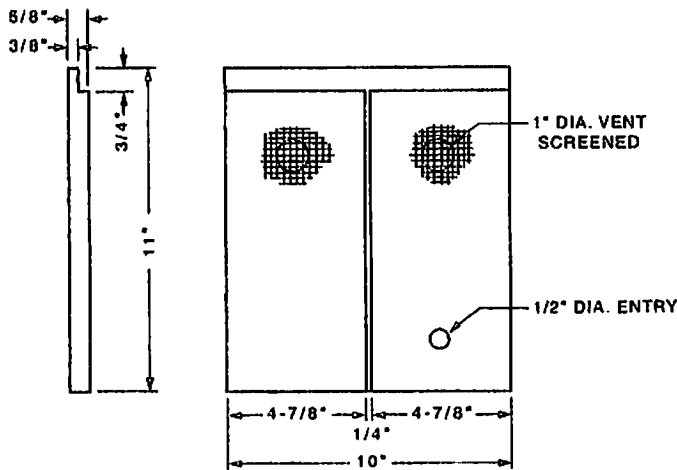

PART NO. 8 - END

PART NO.	LOCATION	SIZE
1	BOTTOM SUPPORT	1-1/2" x 10" x 3/4"
2	TOP RAIL	1-1/2" x 19-3/4" x 3/4"
3	TOP RAIL	1-1/2" x 12-3/4" x 3/4"
4	TOP	11-1/2" x 10-3/4" x 5/8"
5	BOTTOM	10" x 18-1/2" x 5/8"
6	DIVIDER	10-3/8" x 18-7/8" x 1/8"
7	INTER-TOP	4-7/8" x 18-1/2" x 5/8"
8	SIDE	11" x 19-3/4" x 5/8"

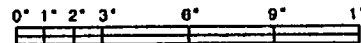

NOTE:

- PART NO. 6 AND NO. 7 TO BE REMOVABLE. DO NOT GLUE OR NAIL.
- PARTS NO. 1, 2 AND 3 MADE FROM 1x2 PINE OR CYPRESS.
- PART NO. 8 MADE FROM 1/8" EXT. A-A PLYWOOD.
- ALL OTHER PARTS OF 5/8" EXT. A-A PLYWOOD.
- TREAT ALL PARTS WITH PENTA SOLUTION.

NOTE: BASED ON UNIV. OF FLA. PLAN NOS. 907 AND 924-R

COOPERATIVE EXTENSION WORK IN AGRICULTURE AND HOME ECONOMICS		
<small>AND UNITED STATES DEPARTMENT OF AGRICULTURE COOPERATING</small>		
6 DEEP BROOD HIVE		
EX. 6327	SHEET 1 OF 1	

FIVE DEEP BROOD
FRAME HIVE
 NOT TO SCALE

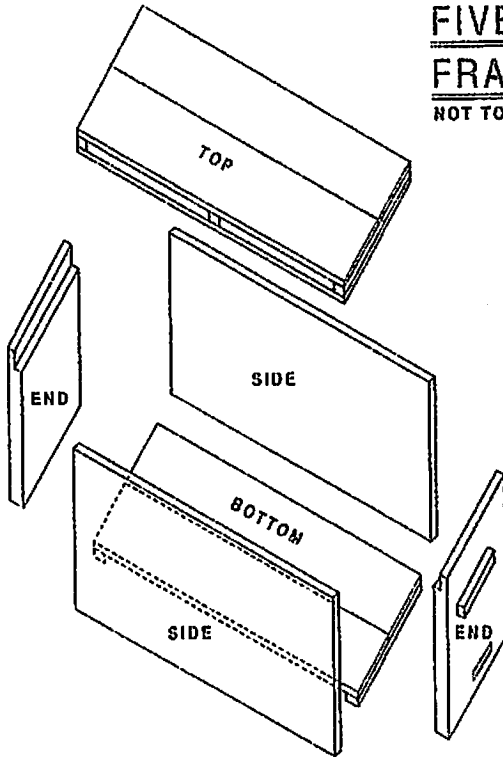

EXPLODED ISOMETRIC VIEW
 NOT TO SCALE

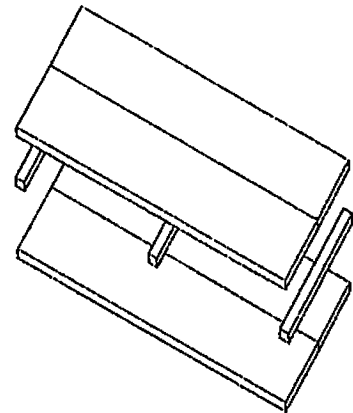

EXPLODED VIEW OF TOP
 NOT TO SCALE

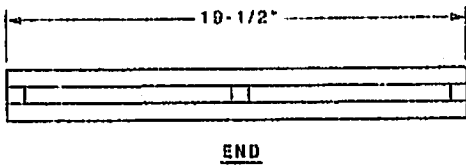
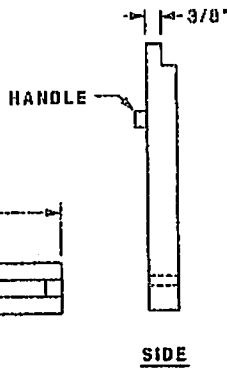
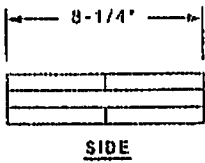

VIEW OF TOP

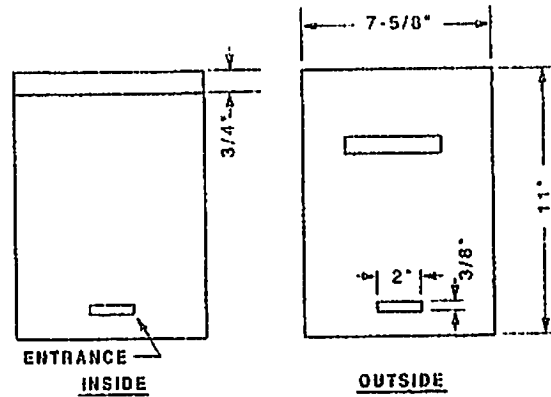

VIEW OF END

COOPERATIVE EXTENSION WORK IN AGRICULTURE AND HOME ECONOMICS	
AND UNITED STATES DEPARTMENT OF AGRICULTURE COOPERATING	
5 DEEP BROOD HIVE	
EX. 6327	SHEET 1 OF 1

10-FRAME LANGSTROTH BEEHIVE

CONSTRUCTION DETAILS FOR 3/4" THICK LUMBER

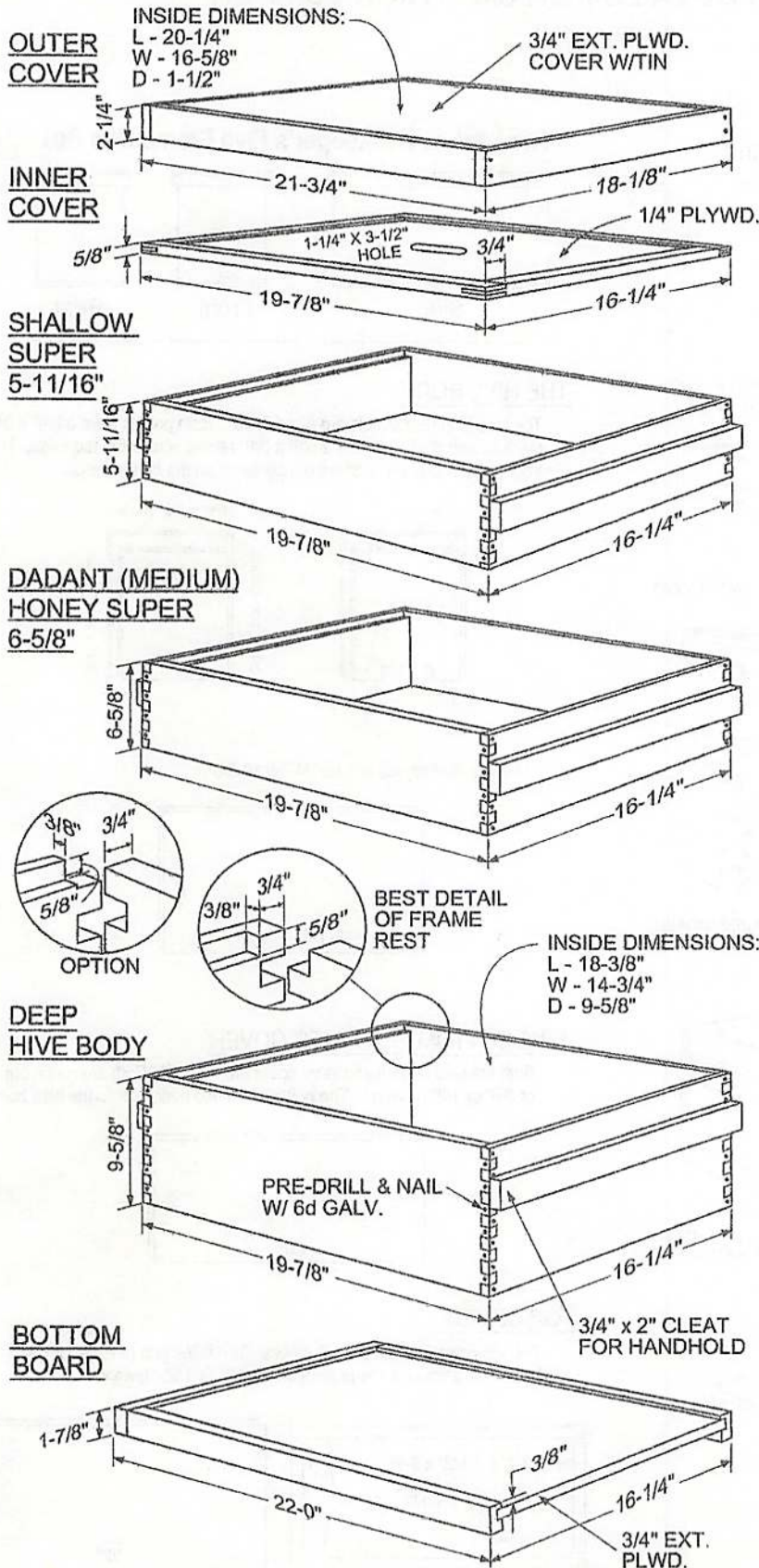

The species of wood used to make a beehive can vary depending upon what is available in your area. The minimum thickness should not be less than 3/4". If you are using standard dimensional lumber, you can use 1x8 (3/4" x 7-1/4") for both shallow and medium super, and 1x12 (3/4" x 11-1/4") for the deep hive body.

Start by cutting the boards to length. For fronts and backs, cut them a smidgen over 16-1/4". For sides, cut a smidgen over 19-7/8". At this point, follow the steps described on how to make a box joint from the PDF 'Box Joint' files.

Now that you have the joint cut and the boards cut to finished size, cut the 5/8" x 3/8" rabbet on the 16-1/4" boards stopping just short of the box joint pin at each end. (Chisel these square after the boards are assembled). Note detail of frame rest at left. Pre-drill holes for nails in each pin.

Assemble boxes with glue and nail each pin with a 6d galv. nail. Attach 1x2 handholds with screws and glue. Attach metal rabbets on the frame rest notch. Fill any holes and paint all surfaces, both outside and inside and top and bottom edges, with two coats of paint.

© 1999.BeeSource.com - All Rights Reserved.
info@beesource.com/www.beesource.com
Reproduction for personal and non-profit use only.



5-FRAME LANGSTROTH NUCLEUS HIVE

CONSTRUCTION DETAILS FOR 3/4" THICK LUMBER

Refer to '10-Frame Langstroth Beehive' and 'How to Make a Box Joint' plans for details on construction.

OUTER COVER

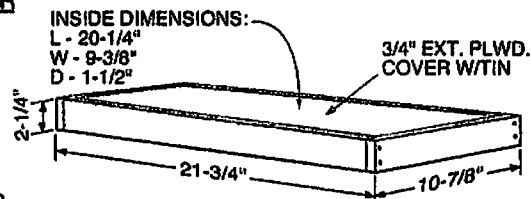

INNER COVER

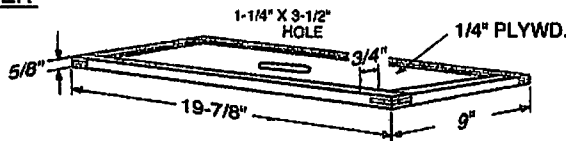

OPTION A

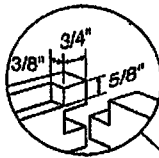

OPTION B

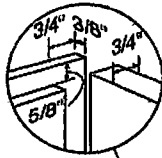

OPTION C

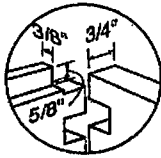

DEEP HIVE BODY

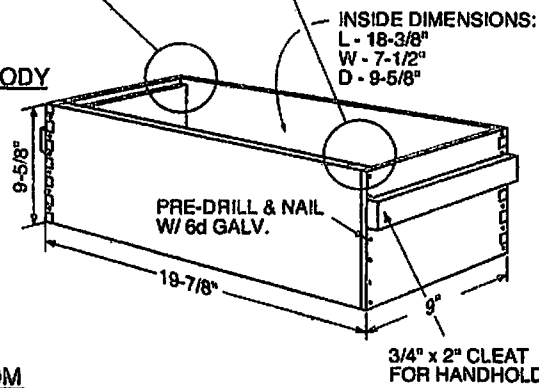

BOTTOM BOARD

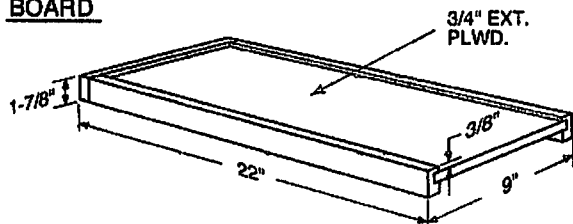

©.1999.BeeSource.com - All Rights Reserved.
 Info@beesource.com/www.beesource.com
 Reproduction for personal and non-profit use only.

The Yankee Beekeeper's Five Frame Nuc Box

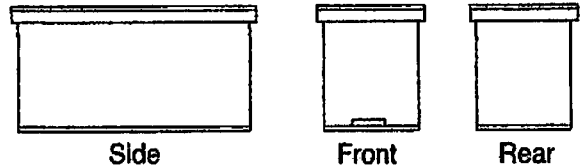

THE HIVE BODY

The front and rear panels are 9" x 10-3/8". Both panels have a 3/4" x 3/8" rabbet down each side and a 5/8" x 3/8" rabbet across the top edge. The front panel has a 3/4" x 3" cut out centered on the bottom edge.

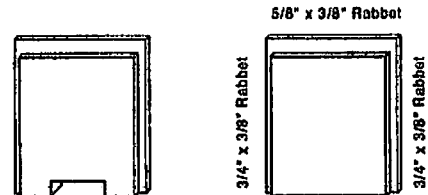

The two side panels are 19-1/4" by 10-3/8".

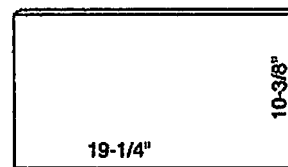

HIVE BOTTOM AND INNER COVER

Both the hive bottom and inner cover are 20" x 9". Both are made out of 3/8" or 1/2" plywood. The bottom is nailed directly onto the hive body.

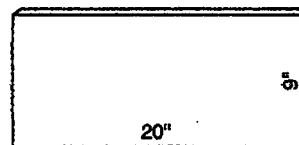

TOP COVER

The top cover is made from 5 pieces. The stiles and rails are detailed below. The cover is made from either 3/8" or 1/2" plywood.

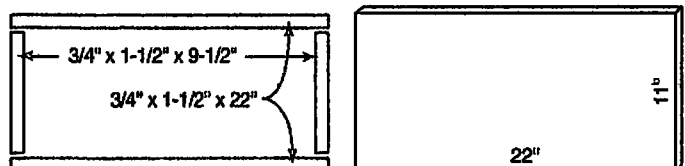

FOUNDATION FORM BOARD

(FOR 9-1/8", 6-1/4" AND 5-3/8" DADANT TYPE FRAMES)

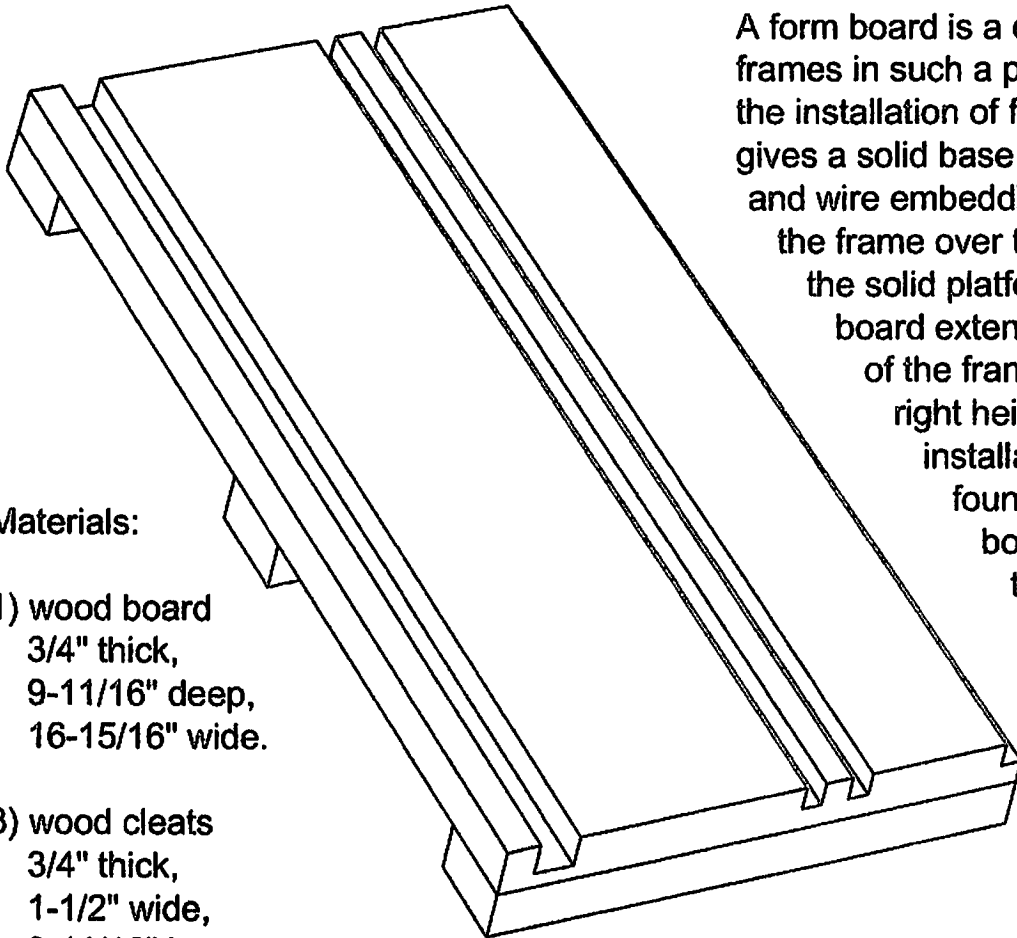

A form board is a device that holds frames in such a position that aids in the installation of foundation and gives a solid base for wedge nailing and wire embedding. Simply place the frame over the form board so the solid platform of the form board extends into the middle of the frame, making it the right height for easy installation of the foundation into the bottom bar. Nail the top wedge in and embed wire if needed.

Materials:

- 1) wood board
3/4" thick,
9-11/16" deep,
16-15/16" wide.

- 3) wood cleats
3/4" thick,
1-1/2" wide,
9-11/16" long.

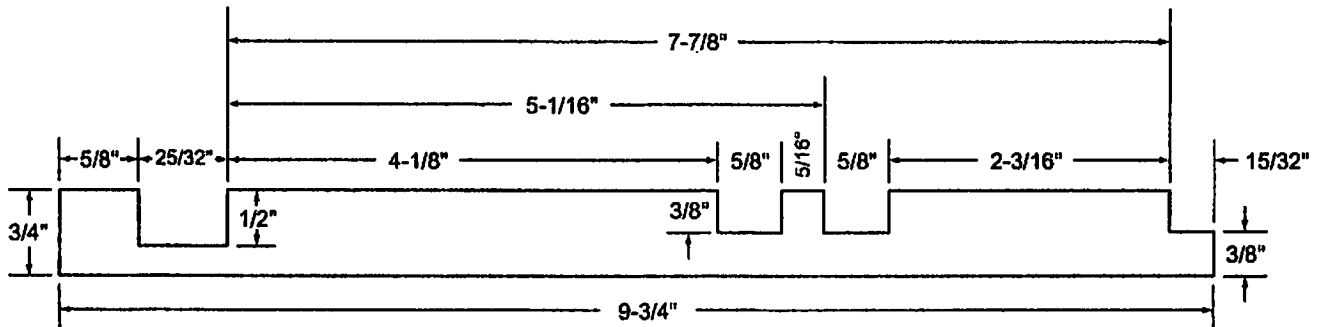

DADANT TYPE FRAMES

(FOR LANGSTROTH HIVE)

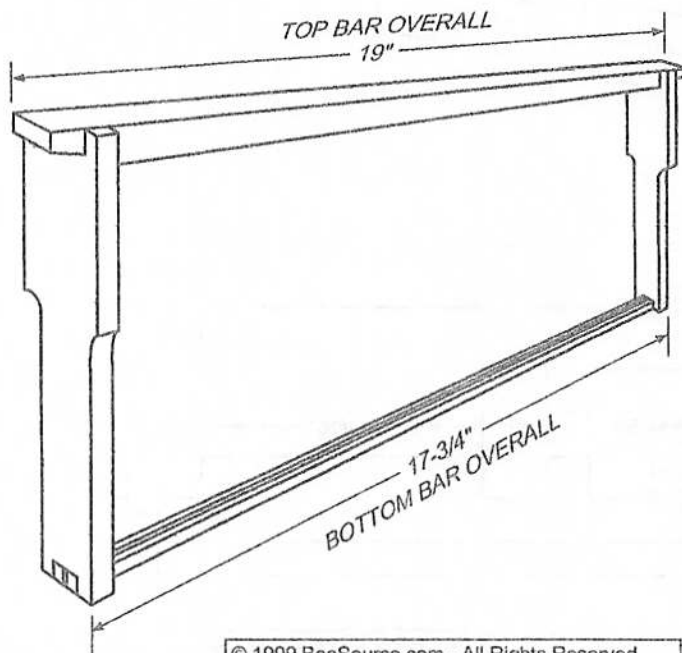
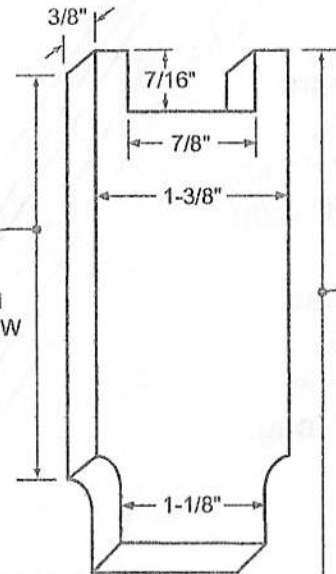
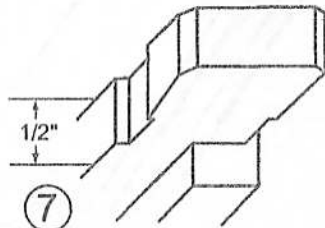
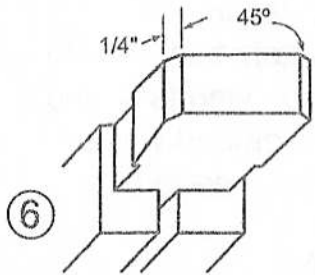
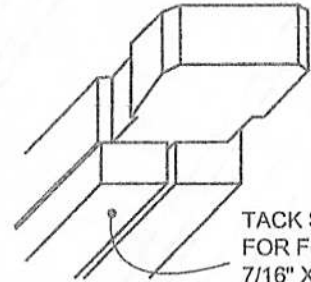
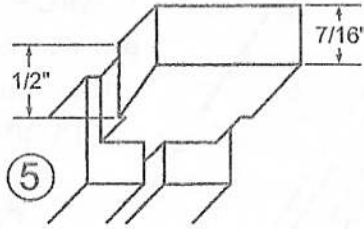
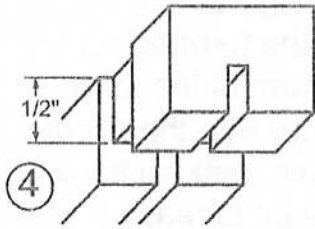
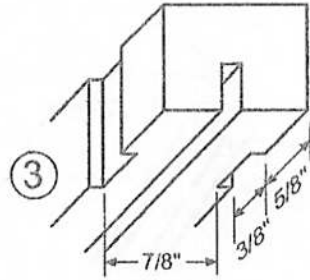
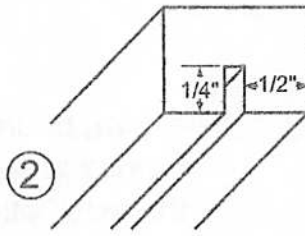
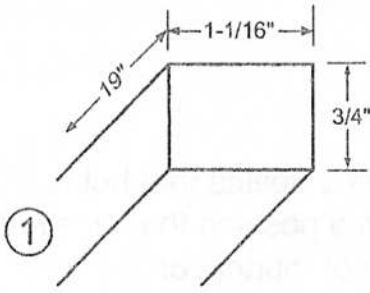

3-1/2" - DEEP
2-5/8" - MEDIUM
2-1/8" - SHALLOW

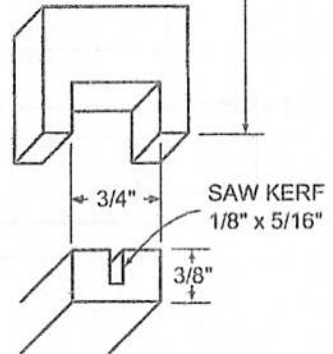

©.1999.BeeSource.com - All Rights Reserved.
info@beesource.com/www.beesource.com
Reproduction for personal and non-profit use only.

MILLER TYPE FEEDER

CONSTRUCTION DETAILS FOR 3/4" THICK LUMBER

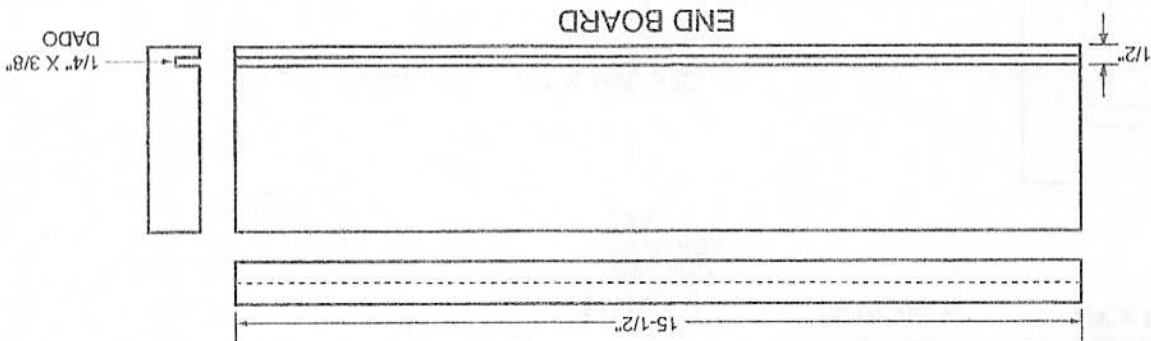
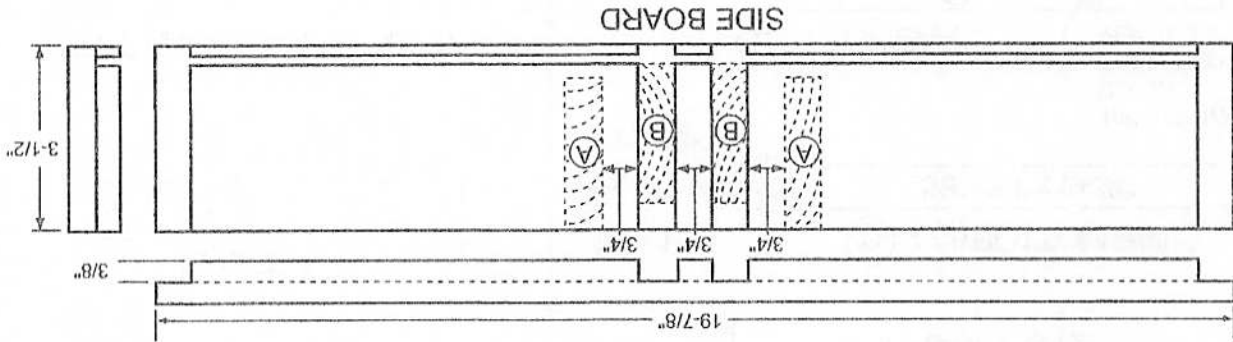
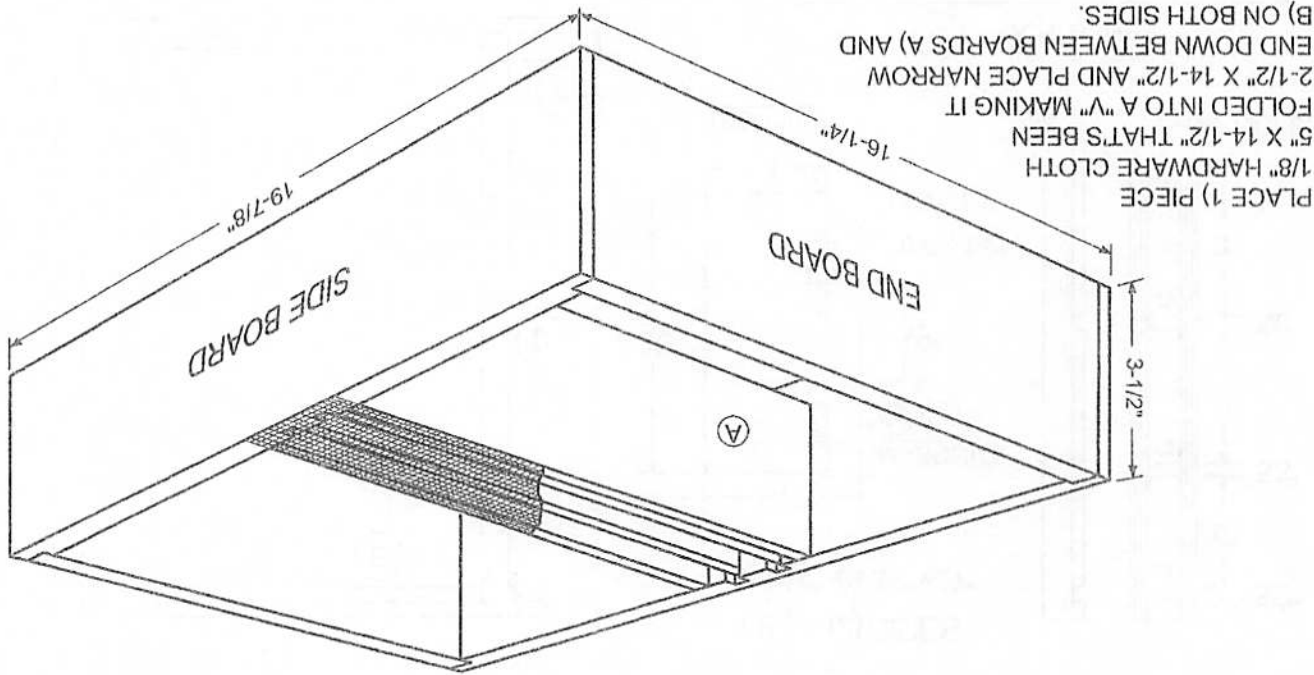

MATERIAL LIST:

- 2) SIDE BOARDS 3/4" X 3-1/2" X 19-7/8"
- 2) END BOARDS 3/4" X 3-1/2" X 15-1/2"
- 2) BOARD "A" 3/4" X 2-5/8" X 14-3/4"
- 2) BOARD "B" 3/4" X 2-1/2" X 15-1/2"
- 2) BOTTOM BOARDS 1/4" X 9-1/4" X 15-1/2" LUAN PLY.
- 1) PIECE 1/8" HARDWARE CLOTH 5" X 16-1/4"

GIVE ENTIRE INSIDE OF FEEDER TWO COATS OF POLYURETHANE OR MARINE VARNISH. POUR MOLTEN WAX ONTO ALL INSIDE SEAMS. ATTACH HARDWARE CLOTH TO TOP OF BOARDS "A" WITH STAPLES.

3-FRAME OBSERVATION BEE HIVE DETAILS FOR OAK LUMBER

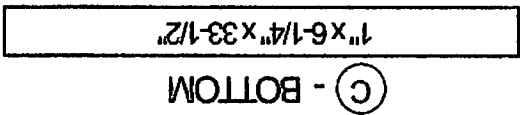
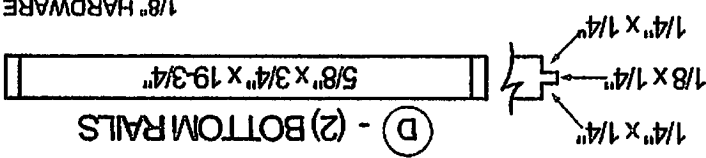
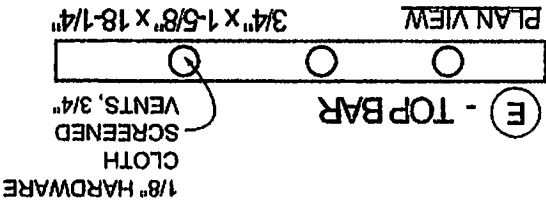
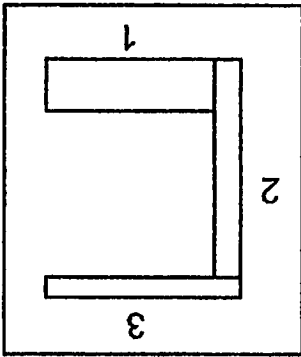
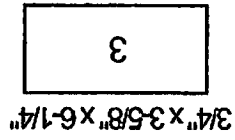
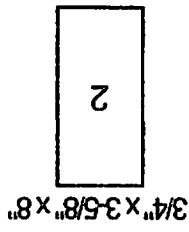
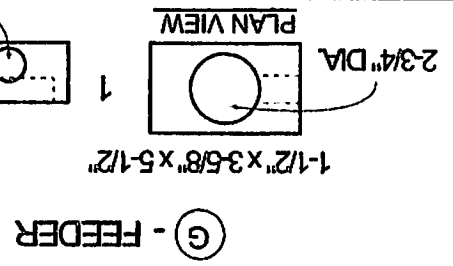
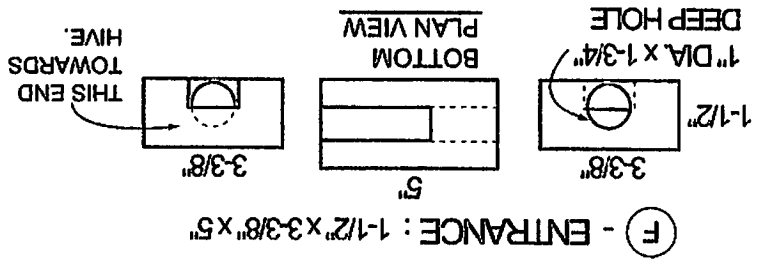
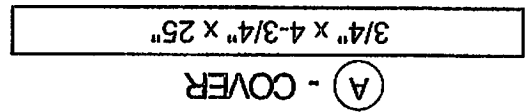
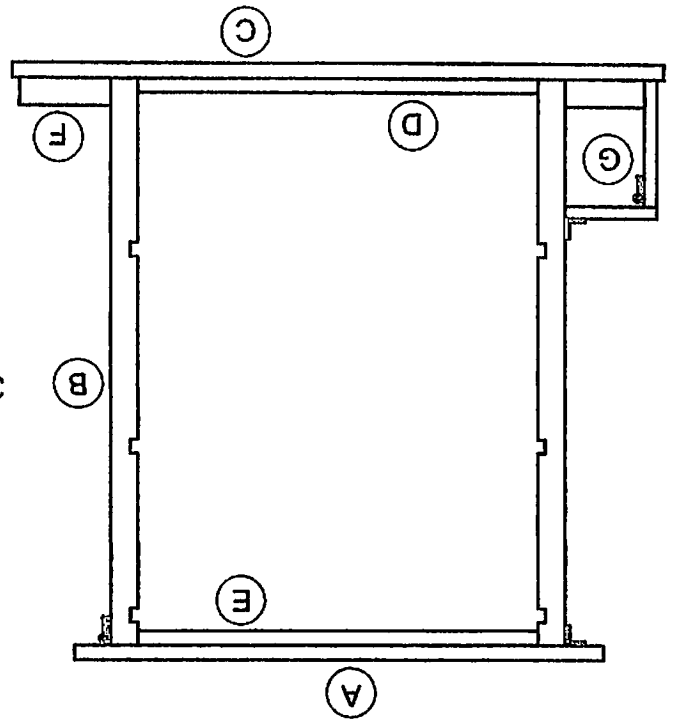
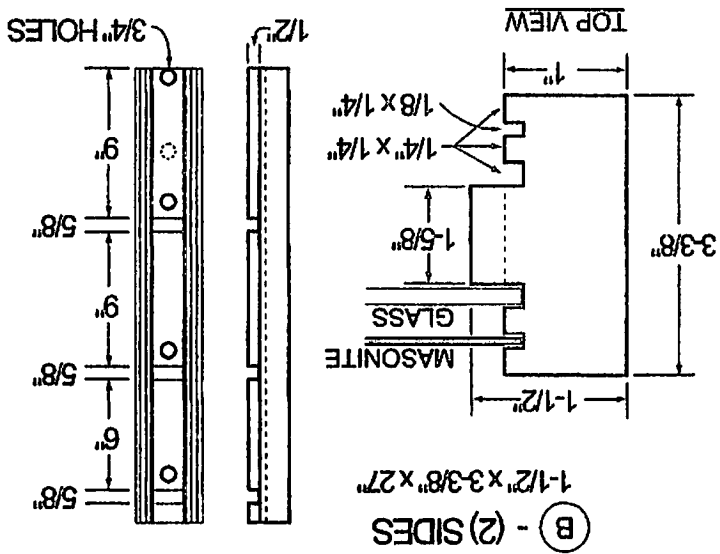

© 1999 Beesource.com - All Rights Reserved.
 info@beesource.com/www.beesource.com
 Reproduction for personal and non-profit use only.

3-FRAME OBSERVATION BEE HIVE DETAILS FOR OAK LUMBER

ADDITIONAL MATERIAL:

- NOTE - DEPENDING ON YOUR USE AND NEEDS OF THE OBSERVATION HIVE, SEVERAL DIFFERENT KINDS OF GLASS AND THICKNESSES CAN BE USED. FOR A LIGHTER WEIGHT HIVE, USE PLEXI-GLASS. IF LONG TERM CLARITY IS DESIRED, USE GLASS. YOU CAN REVERSE THE TWO DADO WIDTHS FOR GLASS AND PANEL IF A THINNER GLASS PANEL IS USED. 1/8" GLASS AND 1/4" PANEL.
- (2) PIECES OF 1/4" PLEXI-GLASS APPROX. 19-5/8" x 27"
- (2) PIECES OF 1/8" HARDBOARD OR LUAN 19-5/8" x 27"
- (2) 3" BRASS HINGES
- (2) BRASS LATCHES THAT CAN BE LOCKED
- 1" CLEAR TUBING (LENGTH AS REQUIRED)
- (1) MASON JAR WITH HOLES DRILLED IN THE COVER

CONSTRUCTION NOTES

- FOR MAKING SIDES, START WITH A PIECE OF 6/4 OAK STOCK ABOUT 8" IN WIDTH. CUT DADO'S FOR FRAME REST'S FIRST THEN RIP THE STOCK INTO TWO PIECES, 3-3/4" WIDE. NEXT, ADJUST FENCE TO 2-7/8" AND CUT DADO, THEN TURN THE STOCK AROUND AND CUT THE OTHER DADO THAT HOLD THE PANELS. NOW SET THE FENCE TO 2-1/2" AND CUT THE DADO THAT HOLDS THE GLASS. GO BACK AND WIDEN THE FIRST DADO'S TO THE THICKNESS OF THE PANEL MATERIAL YOU ARE USING....LUAN, BIRCH PLYWOOD, HARDBOARD.
- THE HEIGHT OF PART (2) FOR THE FEEDER CAN VARY DEPENDING ON THE JAR USED. ADJUST TO FIT (PINT, QUART, MASON, ETC.) AN ENTRANCE FEEDER CAN BE MODIFIED AND USED IN PLACE OF FEEDER BOTTOM "G" SO THERE'S TIN UNDER THE JAR INSTEAD OF WOOD. DO NOT MOVE THE HIVE WITH THE SUGAR WATER IN THE JAR. PUT AN EMPTY ONE ON FIRST.
- ON ONE OF THE SIDES, DRILL THE BOTTOM VENT HOLE ABOUT HALF WAY UP THE FIRST FRAME SPACE. THIS PREVENTS A CONFLICT WHEN ATTACHING THE FEEDER TOP.
- IF YOU USE SCREWS FOR ATTACHING MEMBERS, THEY CAN BE INSTALLED FROM BOTTOM SO THAT NONE SHOW. THE TOP BAR SCREWS GET COVERED WITH THE LATCH AND HINGE.
- INSTALL A NICE BRASS PULL ON TOP TO ACT AS HANDLE AND ROUT THE EDGES TO GIVE A NICE PROFILE.
- APPLY PETROLEUM JELLY TO THE EDGE OF THE GLASS BEFORE INSTALLING TO PREVENT THE BEES FROM PROPOLIZING THE GLASS TO THE FRAME. IF THEY DO PROPOLIZE, USE A HAIR DRIER ON THE GLASS EDGE TO SOFTEN.

DOUBLE SCREEN BOARD

SIZED FOR LANGSTROTH BEEHIVE

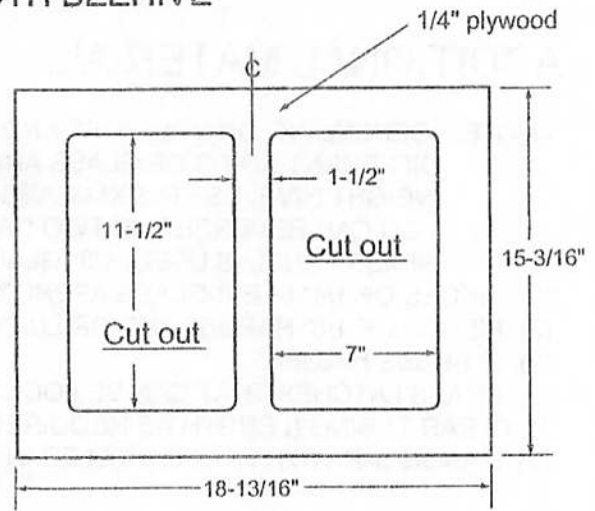
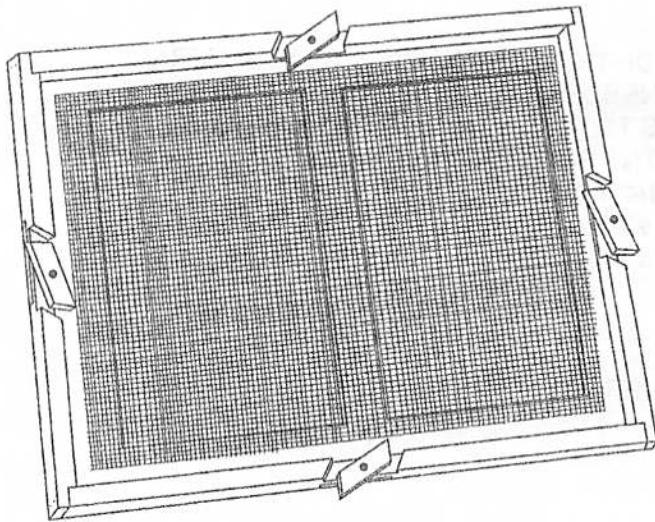

ANGLED PIVOT DOOR

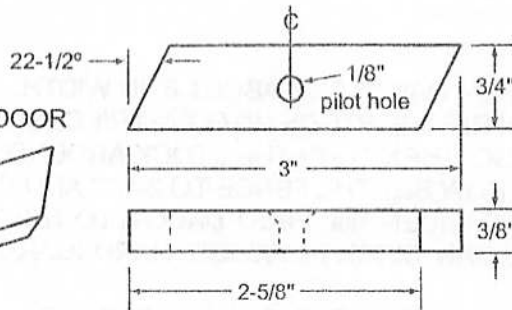
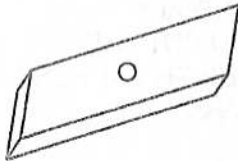

MATERIAL LIST:

- 2) 1/8" hardware cloth / 17-1/2" x 13-1/2" stapled on each side of 1/4" plywood
- 8) 3/8" x 3/4" x 3" angled pivot doors
- 1) 1/4" x 15-3/16" x 18-13/16" plywood
- 2) 3/4" x 1-1/4" x 19-1/8" frame bar
- 2) 3/4" x 1-1/4" x 16-1/4" frame bar
- 8) 3/4" x #6 wood screws for pivot doors

